

## Operation

### To calculate application rate

- Determine the vehicle speed that will be used.
- Place the container on a scale and make note of the weight or tare the scale.
- Measure the weight / mass of the material spread in 30 seconds. Subtract the weight / mass of the container.
- Divide lbs measured in 30 seconds by the intended speed of the vehicle in mph, and multiply by 6.06 to get lbs per 1000 ft<sup>2</sup>.

$$\frac{\text{lbs per 30 seconds}}{\text{intended vehicle speed in mph}} \times 6.06 = \frac{\text{lbs}}{1000\text{ft}^2}$$

$$\frac{\text{kg per 30 seconds}}{\text{intended vehicle speed in kmph}} \times 3.5 = \frac{\text{kg}}{1000\text{m}^2}$$

### Metering Gate Adjustment

To adjust the opening on the metering gate, squeeze lever(A) downward and rotate handle(B) to desired opening. There are 6 gate positions, each position increments the gate by approximately 1/4".

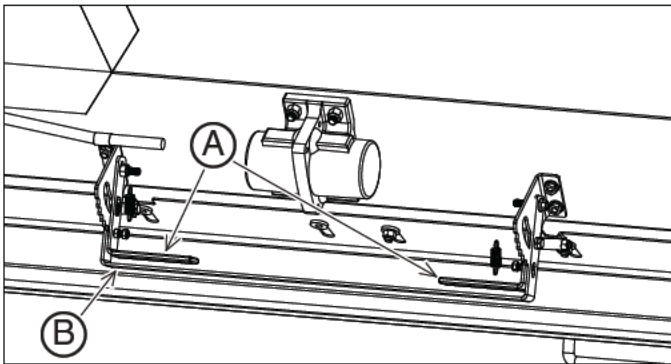

### Preventing and Clearing blockages

Material flows best when material is free of large clumps. If a blockage occurs or material is not spreading, proceed with the following steps until the blockage is cleared.

1. Open the metering gate to a larger position and attempt to spread material again.
2. Turn on the vibrator to help break apart any clumps of material and help the material to flow into the rotor tray. Attempt to spread again.
3. If the rotor is stalled and jammed. Disconnect the spreader harness from the control box. Follow the steps in the cleaning the rotor section.
4. Disconnect power from the spreader. Remove lid and open top grate. Remove any clumped material from the hopper

## Maintenance

Before performing any maintenance, turn off the spreader and park machine safely (see Parking Safely in the Safety section). Unplug the spreader harness from the control box.

### Cleaning Rotor

To clean the rotor area, do not reach down from the top of the machine. The tray housing the rotor is removable.

1. Disconnect the power cord (A) to the drive motor.
2. Lock out the pins (B) on both sides of the machine. When the second pin is pulled, the rear of the tray will drop.



**NOTE:** It is recommended two people remove the rotor assembly

3. Lift pivot bolts (C) off the hooks (D) and the rotor can be removed for cleaning. (Left side shown above)

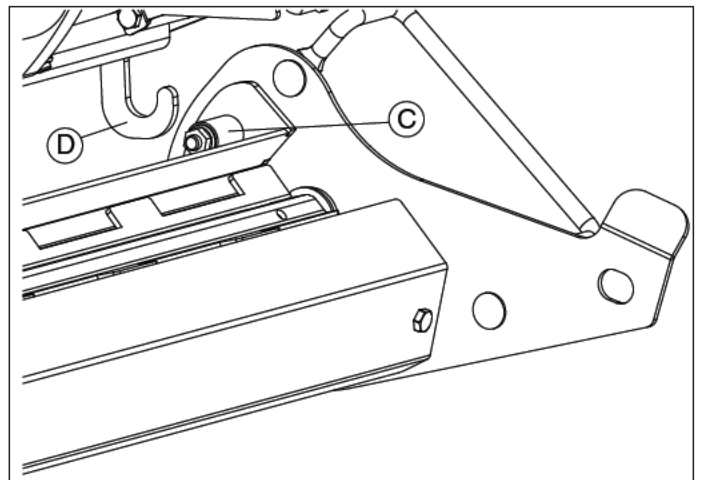

# 45-0593 Drop Spreader 2-In. Receiver

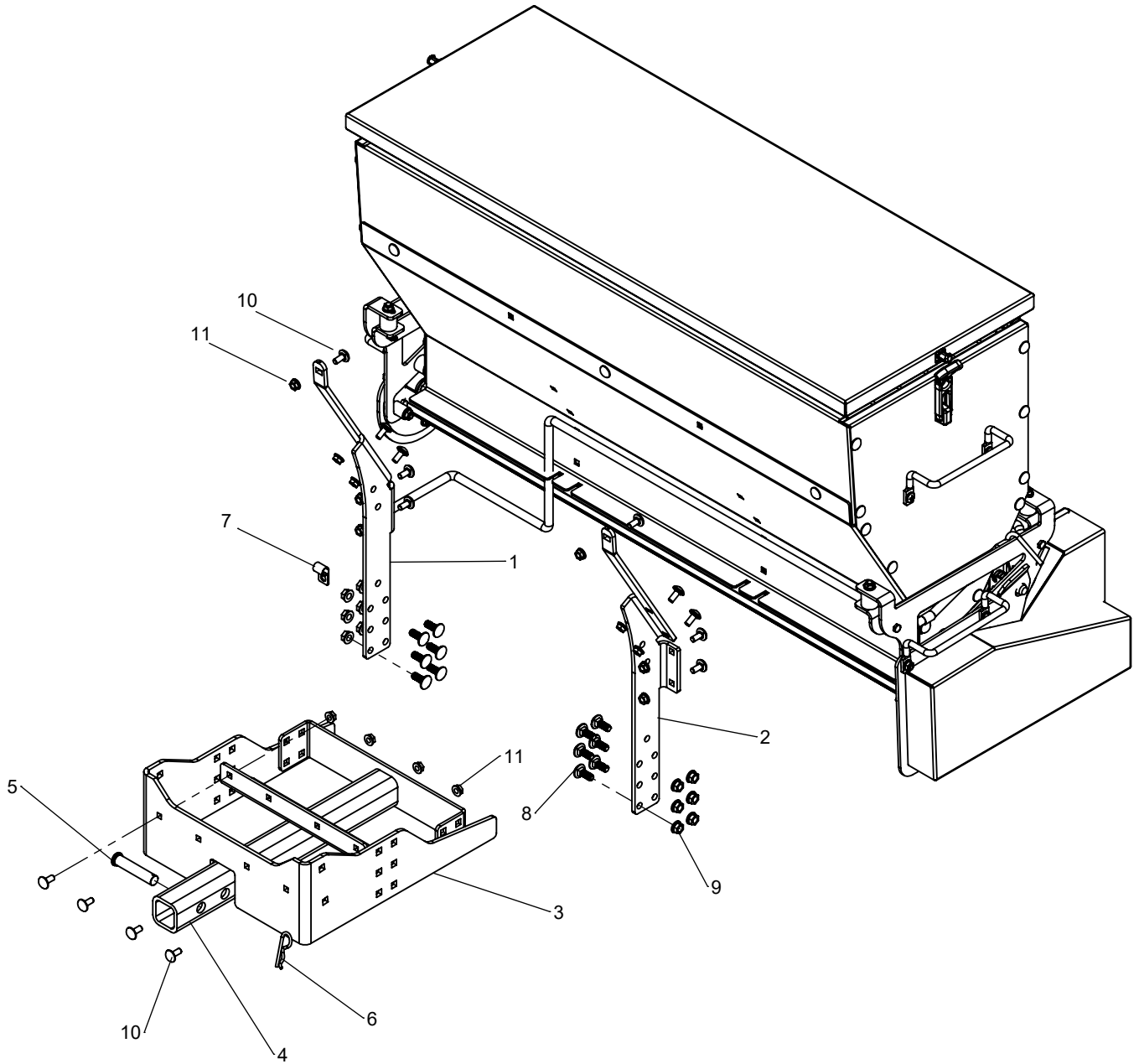

ITEM NO.	PART NUMBER	DESCRIPTION	QTY.
1	ST50454	Leg, Frame	1
2	ST50455	Leg, Frame	1
3	ST50533	Base, Regular profile	1
4	ST50531	2" Receiver Assembly	1
5	ST50373	Clevis Pin $\varnothing 5/8$ " x 3"	1
6	ST43469	Spring Cotter Pin	1
7	ST50468	Clamp, 1/2"ID x .75W Vinyl Coated	1
8	ST65136	Bolt, 3/8" x 1" Carriage S.S.	12
9	ST65126	Nut, 3/8" Flange S.S.	12
10	ST65122	Bolt, 5/16" x 3/4" Carriage S.S.	14
11	ST65124	Nut, 5/16" Flange S.S.	14
Not Shown	ST50306	Spreader Safety Label	2
Not Shown	ST50400	Read Manual Label	2
Not Shown	ST50569	Do Not Ride Label	1
Not Shown	ST50251	TerraKing Label	1
Not Shown	ST50552	Reflective DOT-C2 Tape	2

45-0592 - Drop Spreader with 3-Pt. Hitch Mount

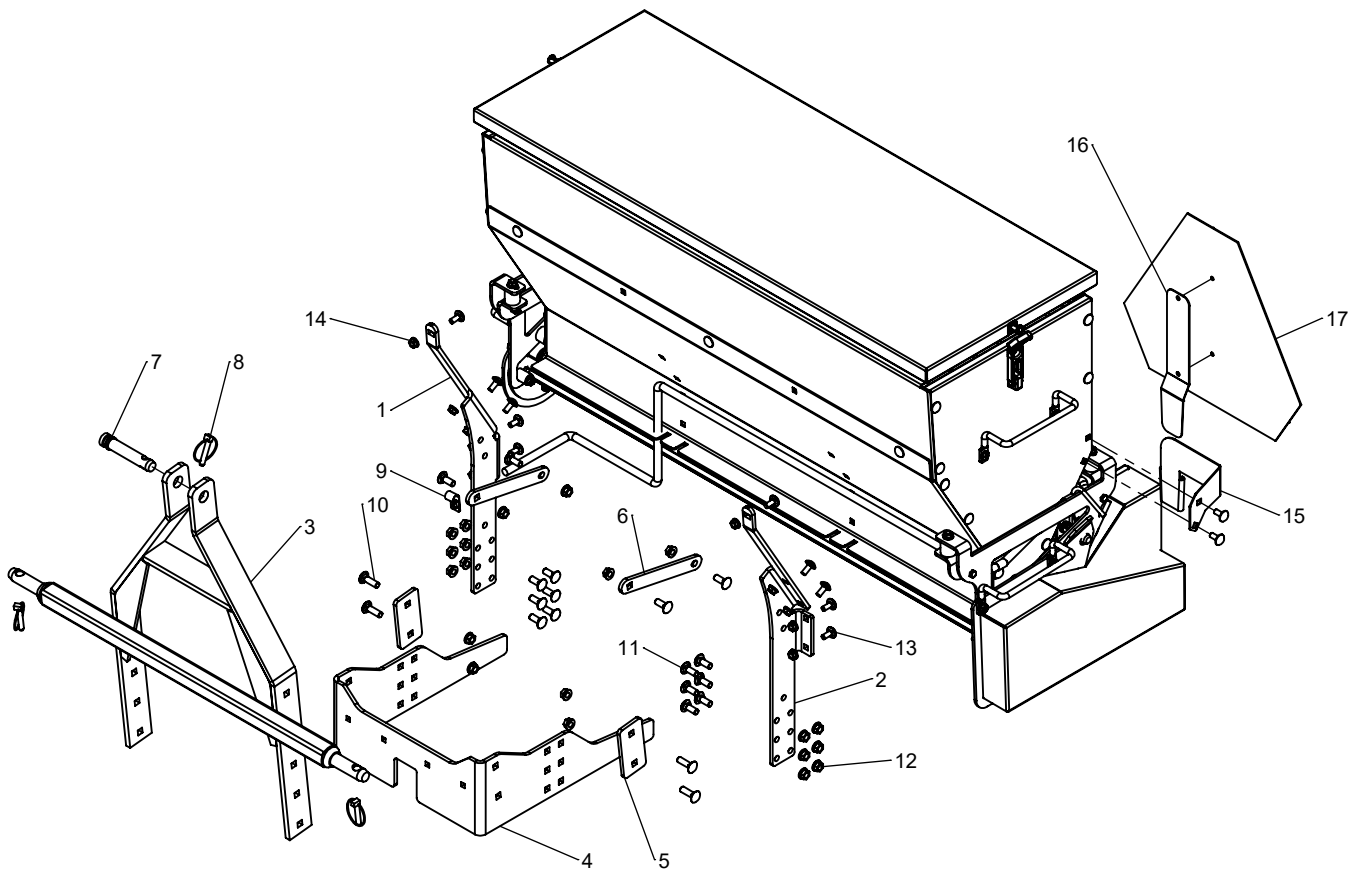

ITEM NO.	PART NUMBER	DESCRIPTION	QTY.
1	ST50454	Frame, Right Leg	1
2	ST50455	Frame, Left Leg	1
3	ST61500	3 Point Hitch A Frame	1
4	ST50533	Frame Base	1
5	ST50527	Frame Spacer	2
6	ST50464	3 Point Hitch Brace	2
7	ST43399	Top Pin, Cat 1	1
8	ST43398	Lynch Pin	3
9	ST50468	Clamp, 1/2"ID x .75W Vinyl Coated	1
10	ST65135	3/8" x 1-1/4" Carriage Bolt S.S.	4
11	ST65136	3/8" x 1" Carriage Bolt S.S.	16
12	ST65126	Nut, 3/8" Flange S.S.	20
13	ST65122	Bolt, 5/16" x 3/4" Carriage S.S.	10
14	ST65124	Nut, 5/16" Flange S.S.	10
15	ST50565	SMV Holder Bracket	1
16	ST50583	SMV mounting spade & Hardware	1
17	ST43647	SMV Sign	1
Not Shown	ST50552	Reflective DOT-C2 Tape	2
Not Shown	ST50306	Spreader Safety Label	2
Not Shown	ST50400	Read Manual Label	2
Not Shown	ST50569	Do Not Ride Label	1
Not Shown	ST50251	TerraKing Label	1

# Drop Spreader Assemblies

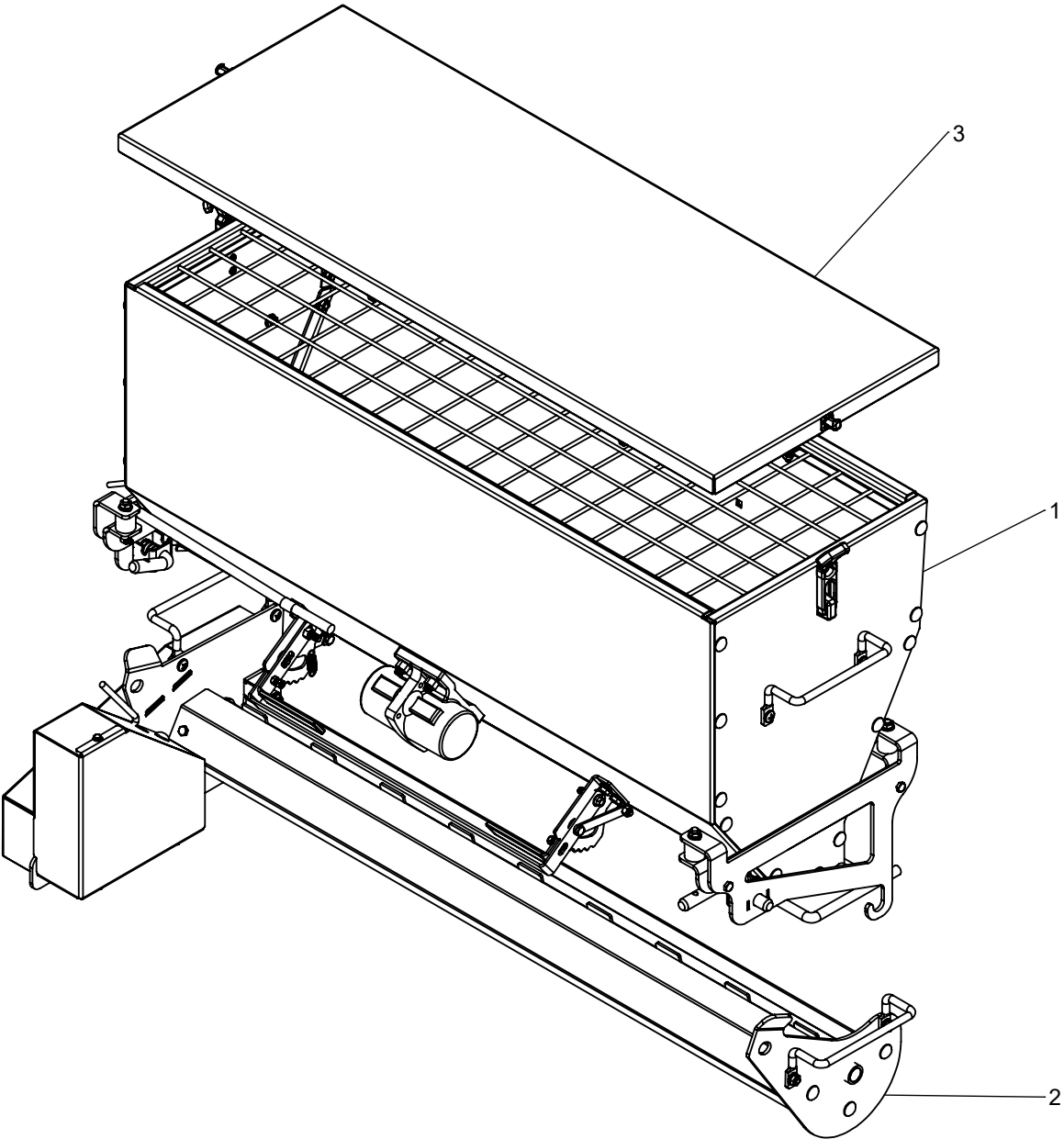

ITEM NO.	PART NUMBER	DESCRIPTION	QTY.
1	SA10018	Hopper Assembly	1
2	ST50478	Tray Assembly	1
3	ST50432	Lid Assembly	1

# SA10018 - Drop Spreader Hopper Assembly

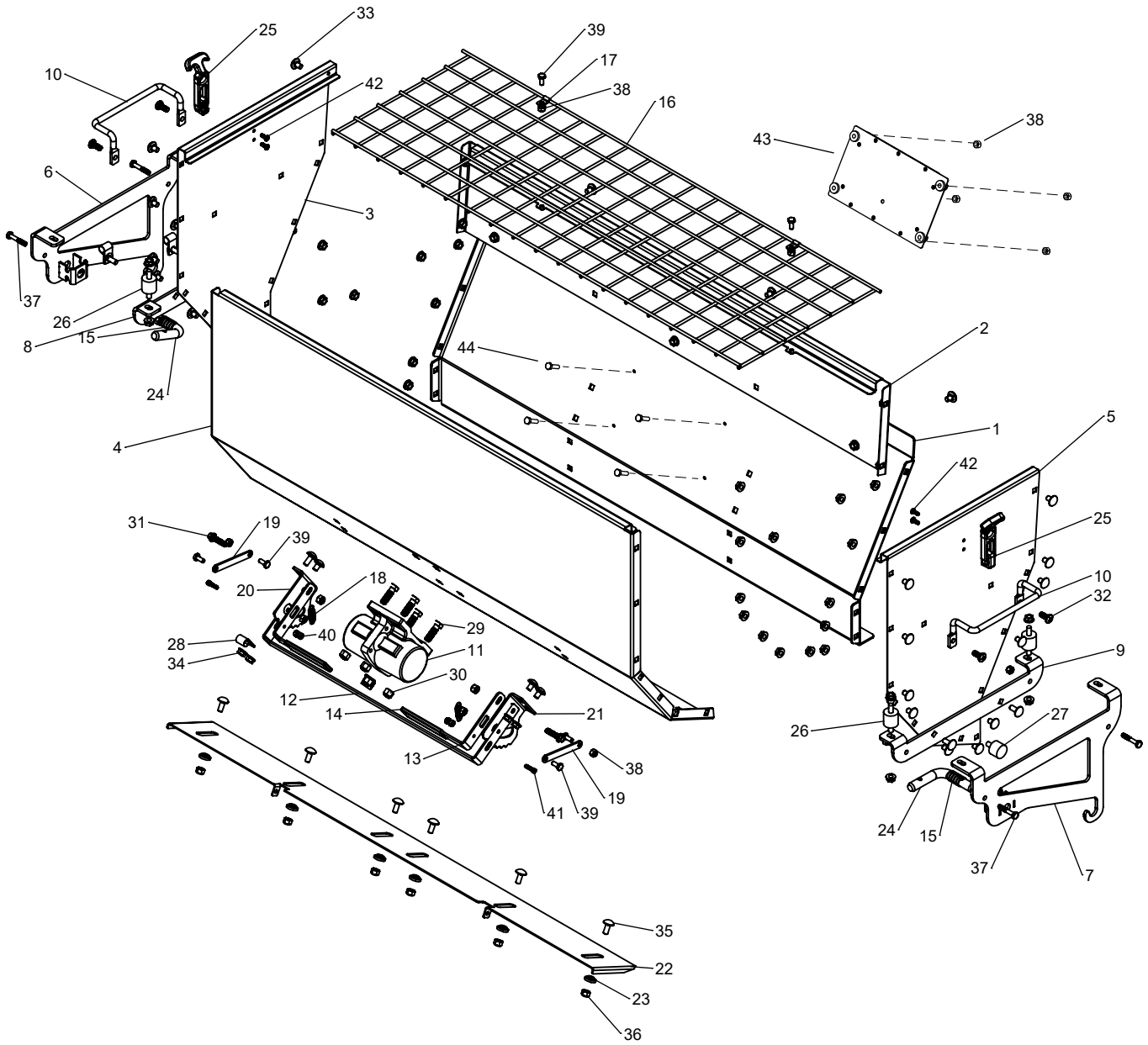

ITEM NO.	PART NUMBER	DESCRIPTION	Standard/QTY.
1	ST50827	Wall, Front Lower Hopper	1
2	ST50410	Wall, Front Upper Hopper	1
3	ST50408	Wall, Left Hopper	1
4	ST50412	Wall, Back Hopper	1
5	ST50409	Wall, Right Hopper	1
6	ST50479	Left Tray Hanger	1
7	ST50480	Right Tray Hanger	1
8	ST50425	Base, Vibration Mount Left	1
9	ST50426	Base, Vibration Mount Right	1
10	ST50447	Handle	2
11	ST50825	Vibrator, 40 lbf	1
12	ST50557	Gate Handle	1
13	ST50558	Gate Latch Lever	2
14	ST50561	Handle Grip	2
15	ST50360	Spring	2
16	ST50450	Grate	1
17	ST50453	Clip	2
18	ST50449	Spring	2
19	ST50562	Linkage	2
20	ST50559	Selector, Gate Position	1
21	ST50560	Selector, Gate Position	1
22	ST50437	Gate, Flow Control	1
23	ST50436	Shoulder Washer USA	6
24	ST50359	Locking Pin 5/8"dia S.S	2
25	ST50451	Rubber Latch	2
26	ST50423	Rubber Isolator	4
27	ST50424	Rubber Bumper	2
28	ST50468	Clamp, 1/2"ID x .75W Vinyl Coated	3
29	ST65138	3/8" x 1-1/4" S.S Hex Bolt	4
30	ST65127	Nut, 3/8" Nylock S.S.	4
31	ST65146	Cap Screw 5/16" x 1-1/4" S.S.	2
32	ST65137	Pan Head Phil.#4 5/16"-18 x 3/4" S.S.	4
33	ST65121	Bolt, 5/16" x 1/2" Short Neck Carriage S.S	26
34	ST65124	Nut, 5/16" Flange S.S.	47
35	ST65122	Bolt, 5/16" x 3/4" Carriage S.S.	13
36	ST65099	Nut, 5/16"-18 Nylock S.S.	8
37	ST65168	1/4" x 1-1/2" S.S. Hex Bolt	4
38	ST65115	1/4"-20 S.S. Nylon Lock Nut	14
39	ST65120	Bolt, 1/4"-20 x 5/8" Hex S.S.	6
40	ST65148	10-24 S.S. Nylon Lock Nut	4
41	ST65147	10-24 x 3/4" Cap Screw S.S.	2
42	ST65130	10-24 #2 S/S Pan Screw	4
43	SA10028	Motor Controller	1
44	ST65224	1/4" x 1" Hex Bolt S.S.	4
Not Shown	ST50828	Motor Harness	1
Not Shown	ST50939	Motor Controller Harness	1
Not Shown	ST50832	Plug 120 Ohm	1
Not Shown	ST50833	3 pin Recpt Cap	1
Not Shown	ST80978	3 pin Plug Cap	1



# ST50478 - Drop Spreader Tray Assembly

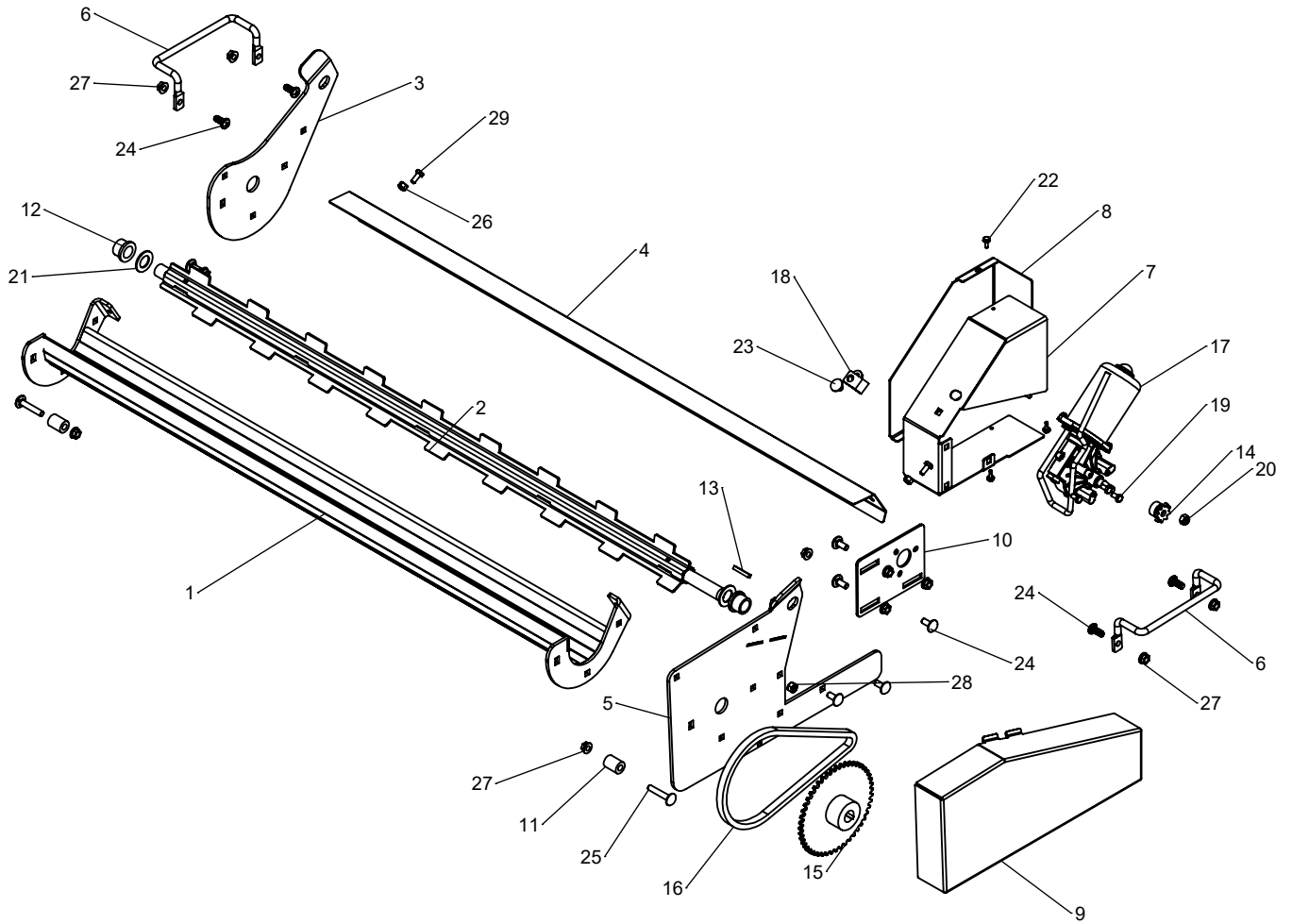

ITEM NO.	PART NUMBER	DESCRIPTION	QTY.
1	ST50473	Tray Weldment	1
2	ST50471	Welded Auger	1
3	ST50430	Plate, Tray Mount Right	1
4	ST50431	Shield, Tray Auger	1
5	ST50445	Plate, Tray Mount Left	1
6	ST50447	Handle	2
7	ST50443	Shield, Motor Inner	1
8	ST50444	Shield, Motor Outer	1
9	ST50446	Shield, Chain Drive	1
10	ST50427	Plate, Motor Mount	1
11	ST50428	Bushing, Tray Hook	2
12	ST50419	Bearing, Bronze Flanged Sleeve	2
13	ST50487	Key 3/16" x 1-1/4"	1
14	ST50435	Sprocket, 35 Series 9T	1
15	ST50472	Sprocket 48 Tooth	1
16	ST50470	Chain, 35 Series	1
17	ST50452	Motor, Electric	1
18	ST50468	Clamp, 1/2"ID x .75W Vinyl Coated	1
19	ST65132	M6 x 12mm Hex Bolt	3
20	ST65128	Nut, M8 Nylock S.S.	1
21	ST65129	Washer, 3/4"ID 1.32"OD Flat S.S.	2
22	ST65131	Screw, #10-24 Thread-Cutting Screw	3
23	ST65121	Bolt, 5/16" x 1/2" Short Neck Carriage S.S	1
24	ST65122	Bolt, 5/16" x 3/4" Carriage S.S.	10
25	ST65123	Bolt, 5/16" x 1-3/4" Carriage S.S.	2
26	ST65115	1/4"-20 S.S. Nylon Lock Nut	2
27	ST65124	Nut, 5/16" Flange S.S.	12
28	ST65099	Nut, 5/16"-18 Nylock S.S.	1
29	ST65120	Bolt, 1/4"-20 x 5/8" Hex S.S.	2

## ST50432 - Drop Spreader Lid Assembly

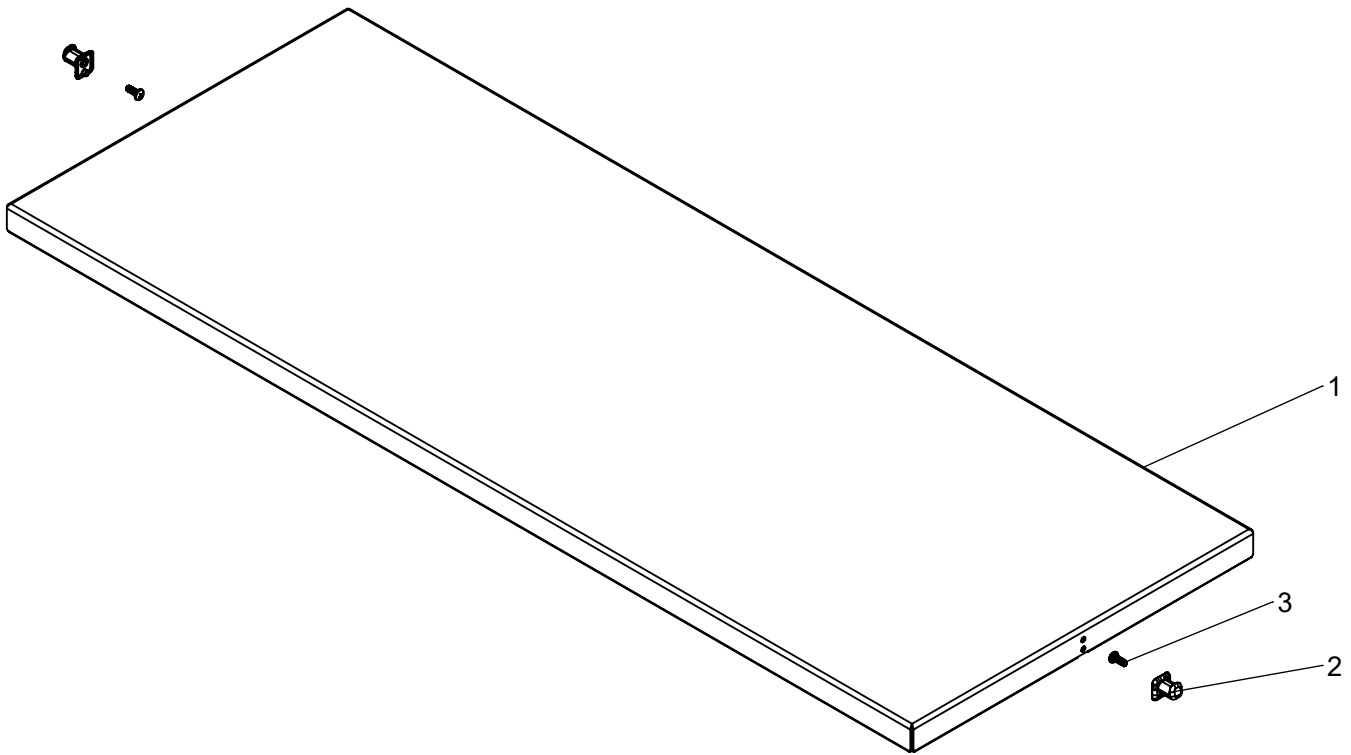

ITEM NO.	PART NUMBER	DESCRIPTION	QTY.
1	ST50432	Lid, Hopper	1
2	ST50451	Latch Stud	2
3	ST65130	Screw, #10-24 1/2" #2 Phil. Pan Head S.S.	2

# SA10051 - Controls and Wiring

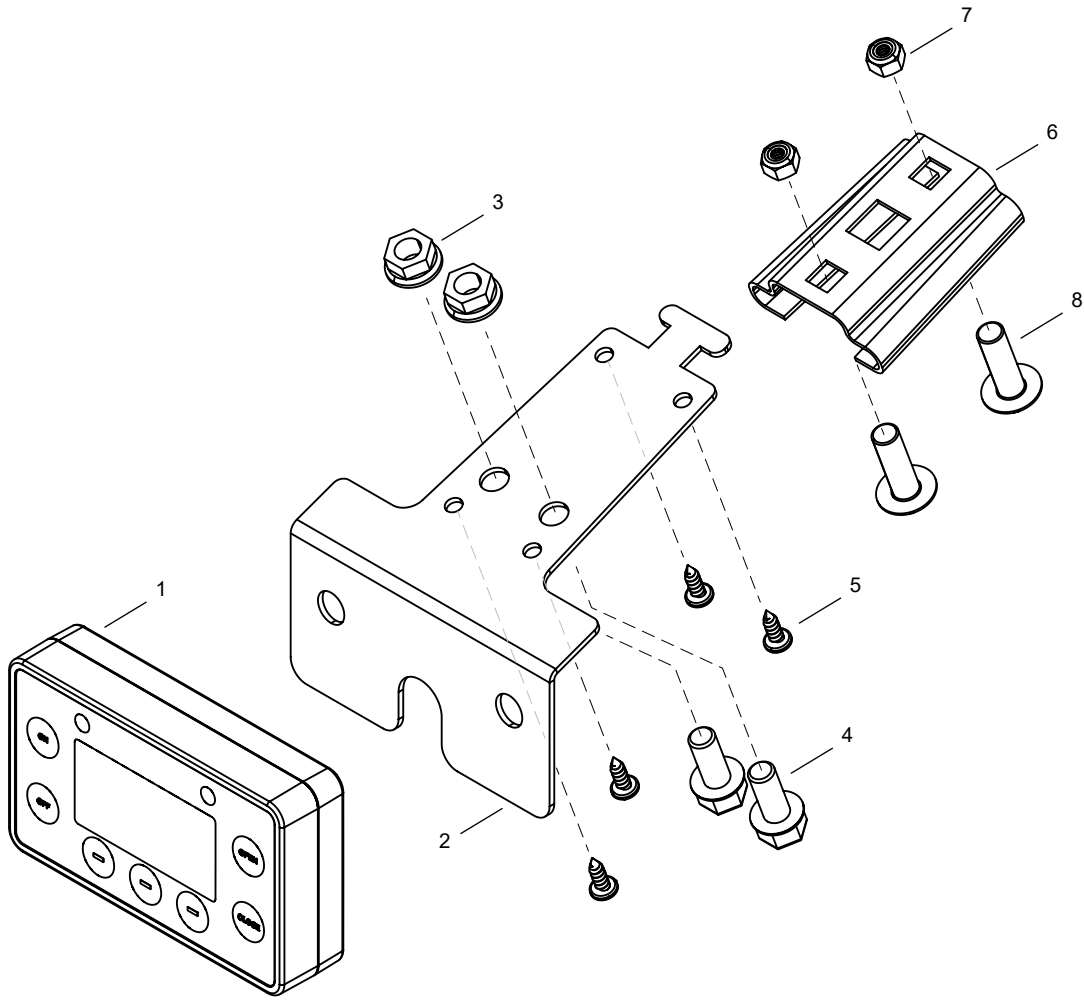

ITEM NO.	PART NUMBER	DESCRIPTION	QTY.
1	ST48613	User Interface, Spreaders	1
2	2-290	Bracket, Universal	1
3	ST65008	5/16" Flange Nut	2
4	ST65007	5/16" x 3/4" Flange Bolt	2
5	ST65182	#8 x 1/2" Sheet Metal Screw	4
6	ST48296	Mounting Socket	1
7	ST65148	#10-24 Nylock Nut S.S.	2
8	ST65001	10-24 x 1" Truss Head Screw	2
Not Shown	2-285	Battery Harness, Universal	1
Not Shown	2-286	Extension Harness, Universal	1
Not Shown	2-459	Display Harness, Universal	1
Not Shown	ST50746	Fuse 32V 30A ATO/ATC (SERVICE PART ONLY)	1
Not Shown	ST50977	P-Clamp	1
Not Shown	ST44006	Wire Tie, Black Nylon UV, 18#, 0.2" wide X 6.0" long	10